

MS5/6NEU-4	MS5/10NEU-4
MS9/6NEU-4	MS9/10NEU-4
MS13/6NEU-4	MS13/10NEU-4
MS17/6NEU-4	MS17/10NEU-4



Dear Customer,
 congratulations on the purchase of the EMP-Centauri product. Before its installation and putting into operation, read carefully the entire operation manual. Keep the purchase and rework (if any) records for future need.

Content

1) Field of Application, Warranty.	1
2) Technical Specifications	2
3) Product Takeover	2
4) Product Storing and Installations	3
5) Product Connection	3
6) Product Settings	5
7) Safety	5
8) Product Maintenance.	5
9) Troubleshooting	5
10) Symbols Explanation.	6
11) Wiring Diagrams	7
12) EMP-Centauri's Related Products	8
13) Contact	8

1) Field of Application, Warranty

The product is designed for the distribution of satellite (SAT), terrestrial (TERR); TV and radio signals, as well as data transmissions between NET CLASS multiswitch and EMP-Centauri's NET CLASS wall sockets. Its purpose is to allow connecting of multiple user to the common satellite antenna, while at the same time providing them internet connectivity over the same coaxial network.

EMP-Centauri's NET CLASS products are covered under 4 (four) years warranty from the date of purchase. The warranty shall not apply to the product used for other than the specified purpose. The user will be responsible for injury or material damage which may arise in consequence of any product use in contradiction with the manual. It is prohibited to dismantle the product and make any interventions in it. Repairs or any interventions in the product may be performed only by EMP-Centauri company, or other companies authorized by EMP-Centauri.

2) Technical Specifications

Products MS5/6NEU-4, MS9/6NEU-4, MS13/6NEU-4 and MS17/6NEU-4 are satellite multiswitches for distribution of terrestrial and satellite signals from up to 4 satellite positions to 6 users, providing data link over the same coaxial cable with bandwidth up to 100 Mbit/s.

Products MS5/10NEU-4, MS9/10NEU-4, MS13/10NEU-4 and MS17/10NEU-4 are satellite multiswitches for distribution of terrestrial and satellite signals from up to 4 satellite positions to 10 users, providing data link over the same coaxial cable with bandwidth up to 100 Mbit/s.

Satellite inputs require use of Quattro LNBS. The terrestrial input features built-in amplifier, which can be switched off and bypassed using rotary knob. The data input supports speeds up to 1Gbit/s, according to standards 802.3i, 802.3u, 802.3ab. The multiswitch is supplied from external power supply PA12 F (included in package) connected to socket DC2.1.

Specification of multiswitch	MS5/6 NEU-4	MS5/10 NEU-4	MS9/6 NEU-4	MS9/10 NEU-4	MS13/6 NEU-4	MS13/10 NEU-4	MS17/6 NEU-4	MS17/10 NEU-4
Number of Inputs / Outputs	5 / 6	5 / 10	9 / 6	9 / 10	13 / 6	13 / 10	17 / 6	17 / 10
Frequency Range	TERR 470–862 MHz, SAT 950–2150 MHz							
Insertion Loss TERR	2 dB active, 20 dB passive							
Insertion Loss SAT	5 dB							
Isolation H/V	20 dB min							
Isolation low/high	25 dB min							
Isolation LNB	-		25 dB min					
Maximum Input level*	TERR 90 dBuV, SAT 105 dBuV							
Maximum Output Level*	TERR 88 dBuV active, 70 dBuV passive, SAT 100 dBuV							
Current Consumption	150 mA (18 V DC) from each satellite receiver							
Data input (port Eth)	10BASE-T (10 Mbit/s), 100BASE-TX (100 Mbit/s), 1000BASE-T (1 Gbit/s)							
Power supply consumption**	15–30 W		18–33 W		21–36 W		24–39 W	
Dimensions (w,d,h)	18.6 x 14.6 x 5.1 cm							
Temperature Range	–25 – +60 °C							

*Terr.: EN 50083-3/60dB IMA3 [dBμV]; SAT: EN 50083-3/35dB IMA3 [dBμV]

** Depends on number of connected wall sockets and actual data activity

3) Product Takeover

Make sure that the product is not damaged and following accessories are enclosed:

- power supply PA12 F
- 75 Ω DC isolated loads for impedancy termination of unused outputs (3 pcs for 6-output products, 5 pcs for 10-outputs products)

In the case of damage or missing accessories please contact your dealer.

4) Product Storing and Installation

We recommend the device to be installed and serviced by the qualified technician.

The product must not be stored and installed:

- in the place with excessive humidity
- in the place with dropping or splashing water,
- in the place with excessive dust pollution, mechanical vibrations or impacts
- in the place out of temperature limits specified in the section 2) Technical Specifications
- close to heat sources (radiators or air ventilators, direct sunshine etc.)
- in the reach of children.

Use the apparatus only in moderate climates (not in tropical climate).

Fix the product firmly on a wall or another hard and inflammable surface with screws and dowels, or to DIN rail using provided plastic holders.

The product shall be in no case held only by the connected cables.

- Ensure the free space for the air circulation (space on sides and bellow the product should be at least 10 cm and the space over its top at least 20 cm).
- Do not cover the product (with curtains etc.).

5) Product Connection

Connect the product in accordance with this manual and valid regulation in you country. Use high quality 75 Ω coaxial cable designed for satellite reception. The coaxial cables shall not be broken, the minimum bending radius should be 5 cm. Mount the F connectors (screw, crimp or compress type) on the ends of coaxial cables, in the case of using the screw F connectors proceed according to the following picture and instructions:



1. Remove the outer coaxial cable coating in the length of approx. 15 mm.
2. Roll up the metal shielding braid and the shielding foil underneath and cut the shielding with scissors to approx. 5 mm.
3. Remove approx. 10 mm of the inner plastic insulation (approx. 5 mm of the insulation remains in a place).
4. Carefully screw the F connector on the cable end until the plastic insulation levels with the F connector opening.
5. Check there is no short between the inner conductor of coaxial cable and F connector.

Connect the F connectors into the F sockets of product and fasten them with an appropriate force.

- Connect input F sockets marked “A” – “D” with converters (LNBS) outputs according to the next table:

Marking of F socket of multiswitch	Marking of outputs of quattro LNB
A	V/L or 12V/0kHz
B	H/L or 18V/0kHz
C	V/H or 12V/22kHz
D	H/H or 18V/22kHz

- Connect input F socket marked “TERR” with output of terrestrial antenna, eventually with output of terrestrial amplifier or channel processing equipment
- Connect socket marked “Eth” using UTP cable with other LAN device (router, switch)
- Connect output F sockets marked “1”, “2”, “3”... with wall sockets NS01-S1 or, if data connection is not required, with any other wall socket. **Attention: DC voltage approx. 9 volts is present at user’s outputs of the multiswitch.**
- It is not allowed to insert any other device between output ports and data wall sockets, the coaxial link should be continuous.
- Connect connector marked with protective bounding symbol with protective bounding conductor, see section 10) Symbols Explanation.

Status LEDs on built-in RJ-45 socket:

LED	Green LED	Orange LED
OFF	Multiswitch is not powered	No data link to router
ON	Multiswitch is powered	Established data link
Blinking		Data activity

The row of green LEDs in the front panel indicates data status of user ports (LED for port 1 is the most left):

LED for user port	Status
OFF	Data operation for user port is disabled
ON	Data connection for user port is active*
Blinking	Ongoing data transfer

* If LED for user port is ON, but data operation fails, restart of multiswitch is necessary, see section 9) Troubleshooting.

The wiring examples are shown in the section 11) Wiring Diagrams or at the website www.emp-centauri.cz.

6) Product Settings

Each connected satellite receiver must be properly set up to have access to all connected LNBs. Follow instruction manual for satellite receiver or TV set. The most common styles of setup are shown in the table:

SAT SYSTEM (LNB)	Setting style 1	Setting style 2	Setting style 3
A	DiSEqC 1.0: 1 of 4	DiSEqC 1.0: A	committed: AA
B (if used)	DiSEqC 1.0: 2 of 4	DiSEqC 1.0: B	committed: AB
C (if used)	DiSEqC 1.0: 3 of 4	DiSEqC 1.0: C	committed: BA
D (if used)	DiSEqC 1.0: 4 of 4	DiSEqC 1.0: D	committed: BB

The rotary knob switches active / passive mode of terrestrial band. Turn the knob clockwise for passive mode and counterclockwise for active mode.

7) Safety

Due to security reasons the product and wiring in which the product is connected, must be grounded properly. Use the terminal identified with the appropriate symbol to ground the product. Make sure the antennas are properly protected against lightning.

Connect all devices to power grid only after all connections are finished and checked.

Never work on the wiring (including satellite and terrestrial receivers, TVs) during or before a storm.

A lightning stroke into the antenna may cause dangerous overvoltage in the product metallic parts.

The product should be disconnected from the wiring immediately if it gets into contact with liquids (dropping water, spilled drinks etc.).

8) Product Maintenance

The maintenance operation is especially cleansing of the product. **Always disconnect the product from the power grid and wiring before performing any maintenance of the product. If you have to enter places with a risk of fall, pay attention to your safety.**

Use only dry cloth to clean the product and do not use any liquid agents.

Coaxial cables installed outdoors should be replaced once in a few years. Unscrew all F connectors and clean connector contacts, resp. shorten the coaxial cable by approx. 2 cm, every 2 years.

Check the state of power supply and its mains cord periodically. If the mains cord or the mains plug of product is damaged, it must be replaced by manufacturer or qualified technician to prevent any dangerous situation. Let the product serviced if the housing of power supply is damaged.

If not used for long time, disconnect the product from the power grid.

9) Troubleshooting

Always disconnect the product from the power grid before working on product, otherwise you risk the electric hazard. Pay attention to your safety if you have to enter places with a risk of fall.

In the case the product does not work and power supply seems to be fine:

- Check if the terrestrial and satellite antennas are correctly fixed, optimally set and connected to the product, satellite and terrestrial receivers turned on, plugged on and correctly set.
- Check the connector connections. The inner conductor of coaxial cable must be in contact with the inner conductor of F socket and the shielding of coaxial cable with F connector.

Replace broken or interrupted coaxial cable.

- Sometimes the reset of the multiswitch microprocessor is enough to fix the problem. Pull out the power plug of the multiswitch and satellite receiver from power grid and then re-plug them a few seconds later.









In the case the product does not work and LED of power supply seems to be overloaded:

- Disconnect the product from the power grid and check that there is no short-circuit on the input satellite coaxial cables, which prevents the power supplying of LNBS. If yes, remove short-circuit and re-plug the product into the power grid again.
- The cause can be current consumption of devices connected to the satellite inputs of product which exceeds the specifications, see section 2) Product Specifications.

Upon the power on the multiswitch tests condition of user ports and deactivates data operation for all ports where EMP-Centauri NET CLASS wall socket is not detected. Anytime later is the port automatically disabled for data operation if physical connection to the data wall socket is lost. Data operation is not activated automatically after re-connection of the wall socket. To re-activate data operation it is necessary to restart the device by short disconnecting and reconnecting of power supply cord.

If the failure cannot be removed, please contact your distributor.

10) Symbols Explanation

	certificate of conformity
	international standard for digital satellite equipment control, number (1.0, 1.1, 1.2 or 2.0) determines DiSEqC version.
	for indoor use only
	DC power supply
	protective bonding
	class II device
	fuse protected
	safety transformer
	According to EU directive, electric and electronic devices which are identified by one of the following symbols must not be disposed of together with municipal waste. When disposing of the old device, use local waste collection and separation systems.

11) Wiring Diagrams

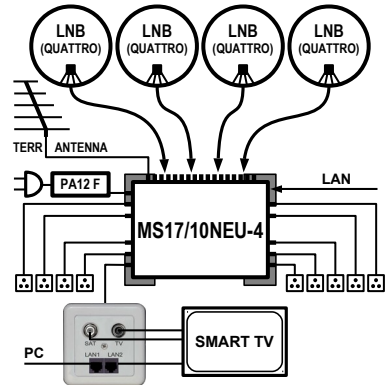
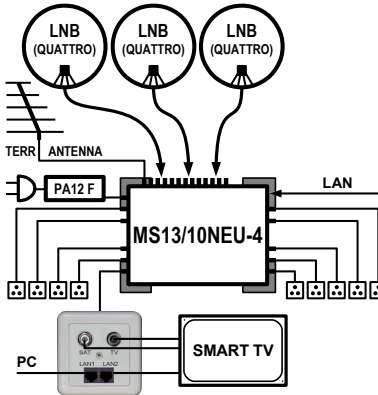
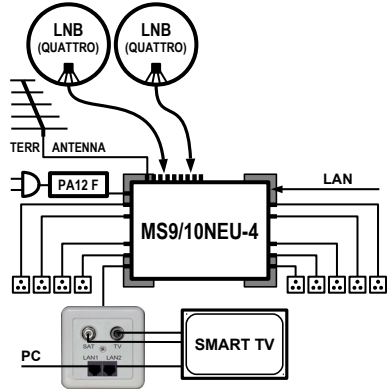
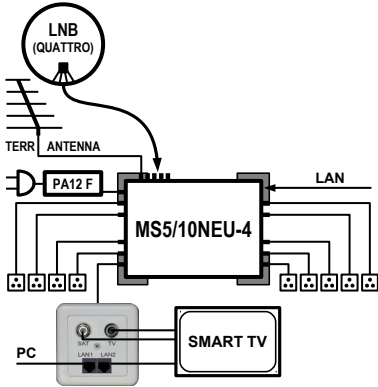

12) EMP-Centauri's Related Products

ES 41-15: Mini terrestrial TV / data headend

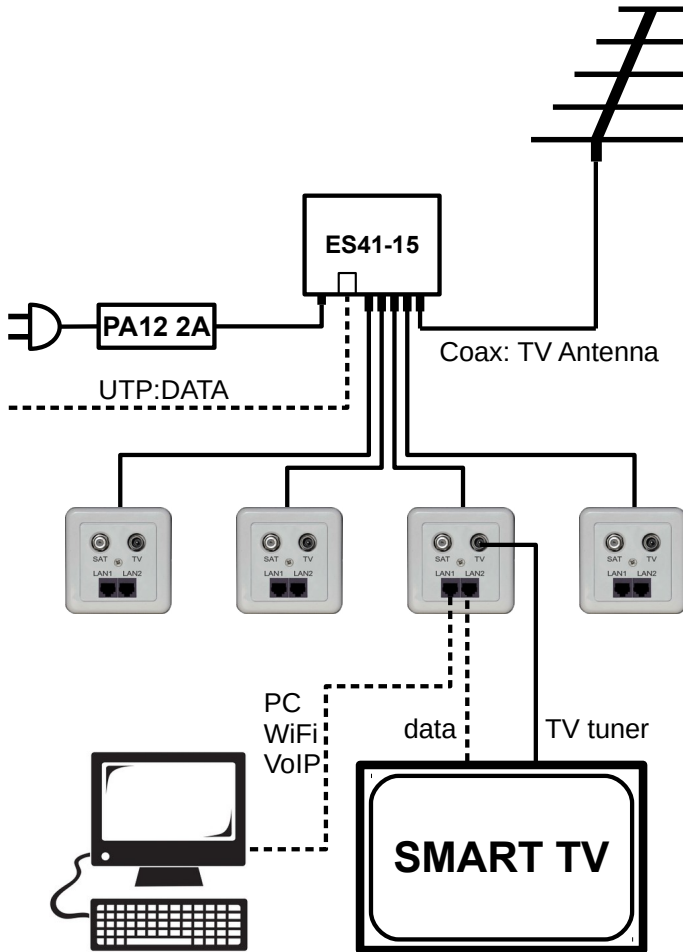

13) Contact

EMP-Centauri s.r.o.
5. kvetna 690
339 01 Klatovy 4
Czech Republic

tel: (+420) 376 314 852
fax: (+420) 376 323 809
info@emp-centauri.cz
www.emp-centauri.cz